

TH135-180 Hydraulisches Spannzeug

- keeping force : 180 kN 315 bar
- 3 rods 50 mm Ø with spring return
Max movement of rod : 15mm
- temperature range: 0 °C - +70°C
- hydraulic connection: 1/4"
- steel surface black or nickel
- weight: ~ 55kg one head without jaws
- scope of delivery 1 pair

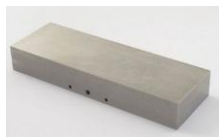

TH135-180 + TH135-P2



Blank jaws
- blank no coating



Pyramid jaws
- steel hardened 58 HRC
- Pyramids 1.2x45°



V-jaws
- for round samples
- steel 58 HRC
- pyramid lines distance 1,2 mm



Wave jaws 5 mm
- Wave distance 5 mm
- steel 58 HRC

Part Number	Surface	Keeping size H x B	opening	weight/ per pair
TH135-180-B	Blank jaws	70 x 210mm	0 - 30 mm	~ 6.7kg
TH135-180-BP	Pyramid jaws	70 x 120mm (70x210)	0 - 30 mm	~ 6.7kg
TH135-180-BV	V-Jaws	70mm	8 - 30 mm Ø	~ 6.7kg
TH135-180-BW	Wave Jaws	70 x 210mm	0 - 20 mm	~ 6.7kg

Scope of delivery jaws 1 Set = 4 jaws
Other dimensions on request

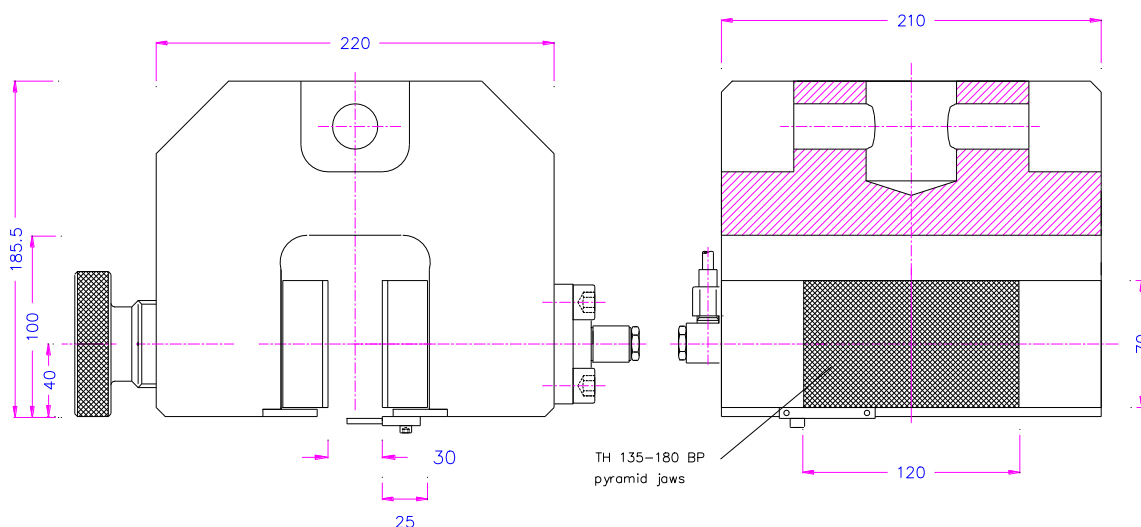

TH135-180

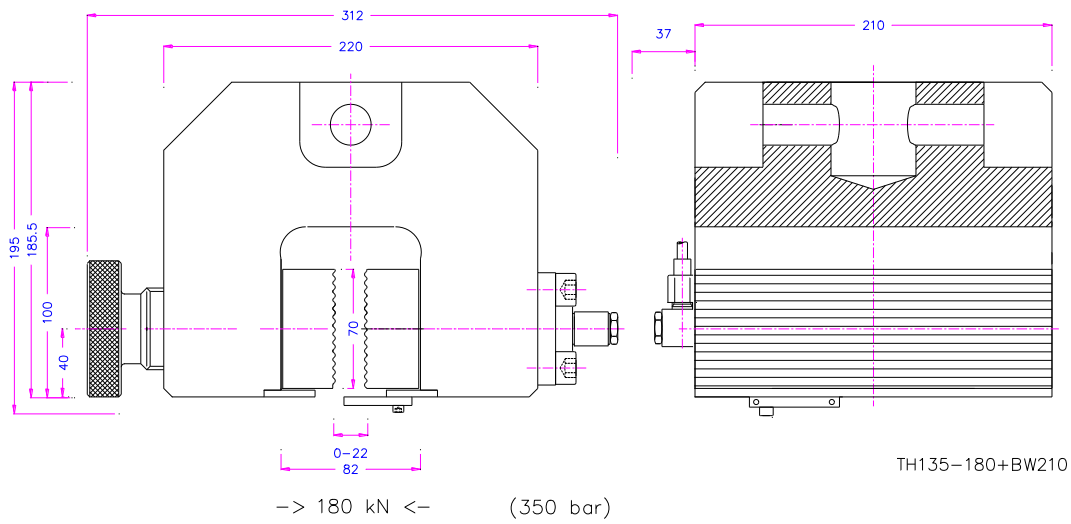

TH135-180 + BW210 with wave jaws for textile samples

	<p>TH135-180-S23</p> <p>Special version for dynamic tests With Guide ball bearings</p>
---	---

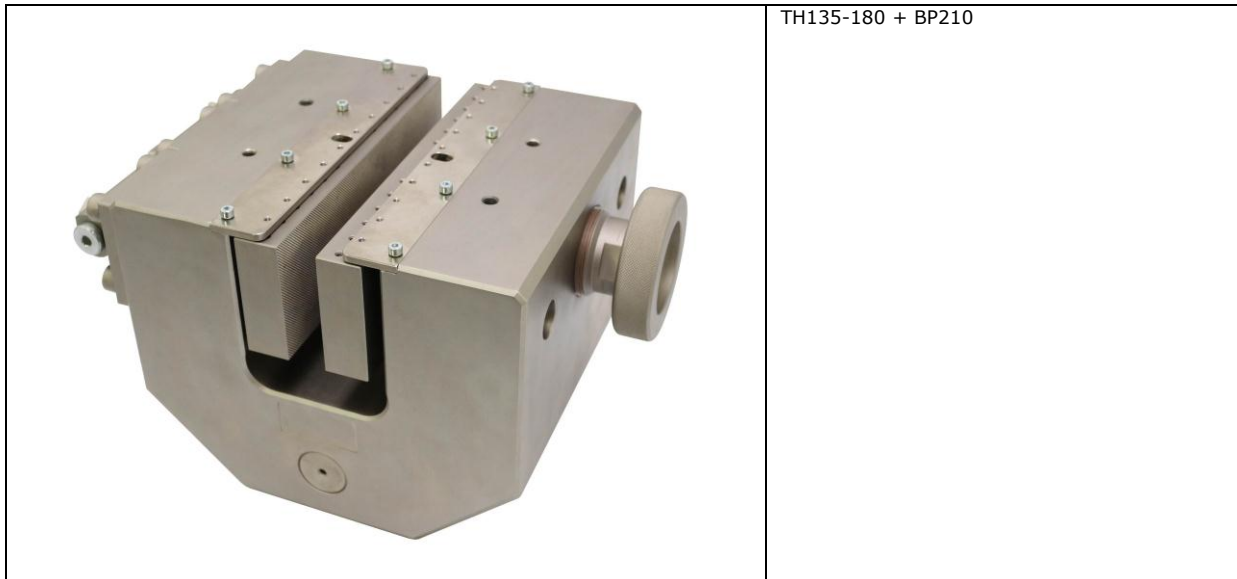
**TH135-P2**

Air pneumatic pump, power pack with 2 magnetic valves and two switches
2.75 Liter/min 350 bar 25 kg 1:61 (1 bar air pressure makes 61 bar oil pressure) Minimum air pressure 1 bar
350x250x400mm 220Volt 0.1 A incl tubes 2x3m

**TH135-P2-G-a**

Air pneumatic pump power pack with 2 magnetic valves and two switches for open and close + 'G' box for noise reduction + 'a' analog input signal for pressure adaptation (1V =40bar, 5V=200bar, 10V=400bar) 220Volt 0.1 A incl tubes 2x 3m

**TH135-P2-2-G-a**

Air pneumatic pump power pack with 4 magnetic valves and two switches for close - stop - open + box for noise reduction + analog input signal for pressure adaptation (1V =40bar, 5V=200bar, 10V=400bar) 220Volt 0.1 A incl tubes 2x3 m

See also www.grip.de/G13 www.grip.de/pdf/TH135-Pu_Datatsheet.pdf